

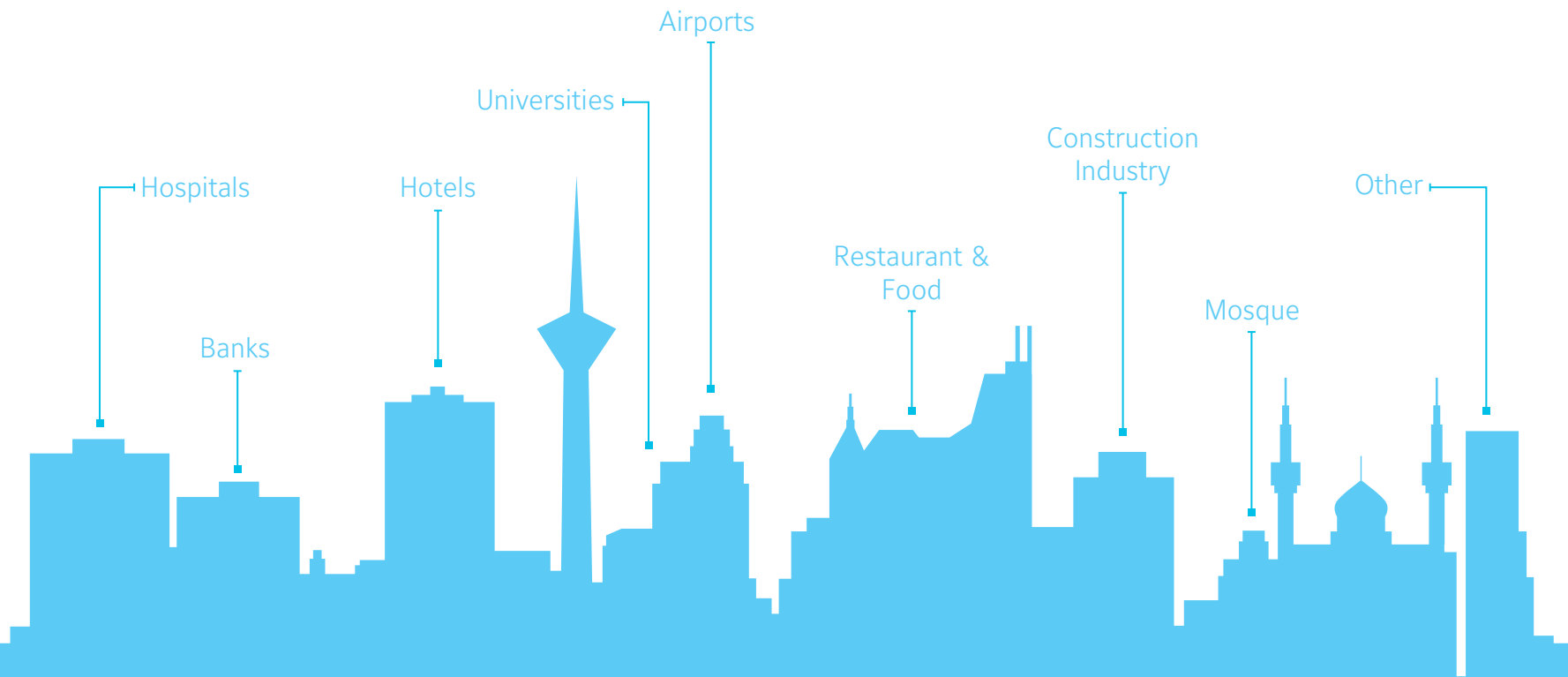

GALVANIZED COOLING TOWER

Saran

Life's Pleasant Breeze



AIR CONDITIONING MFG.GROUP

www.saran-mfg.com
saran@saran-mfg.com



Contents

Nomenclature	4
Introduction	5
Main Features	5
Select Procedure	6
Correction Factor Graph	7
Schematic Drawing	9
Technical Data	10
Service Area	11

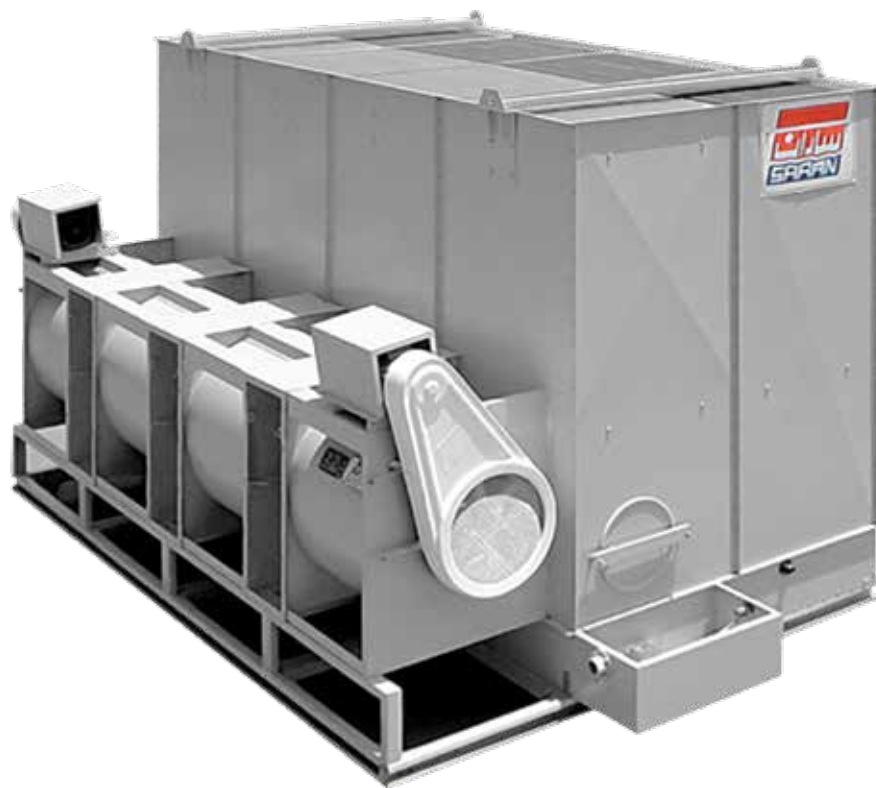

NOMENCLATURE

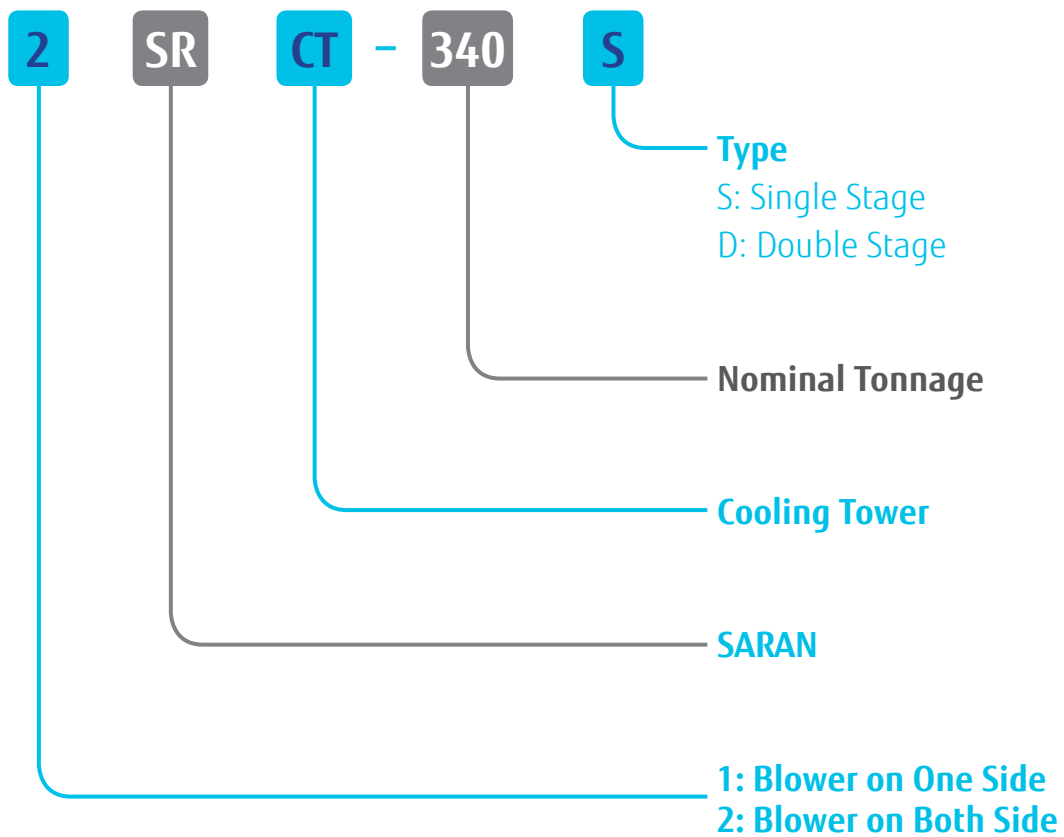

Introduction

Saran galvanized cooling towers offer durability, high performance, whisper quiet operation, low water pressure drop and easy of servicing in capacity range of 10 to 1140 tons of refrigeration in two different types of single and Double stage.

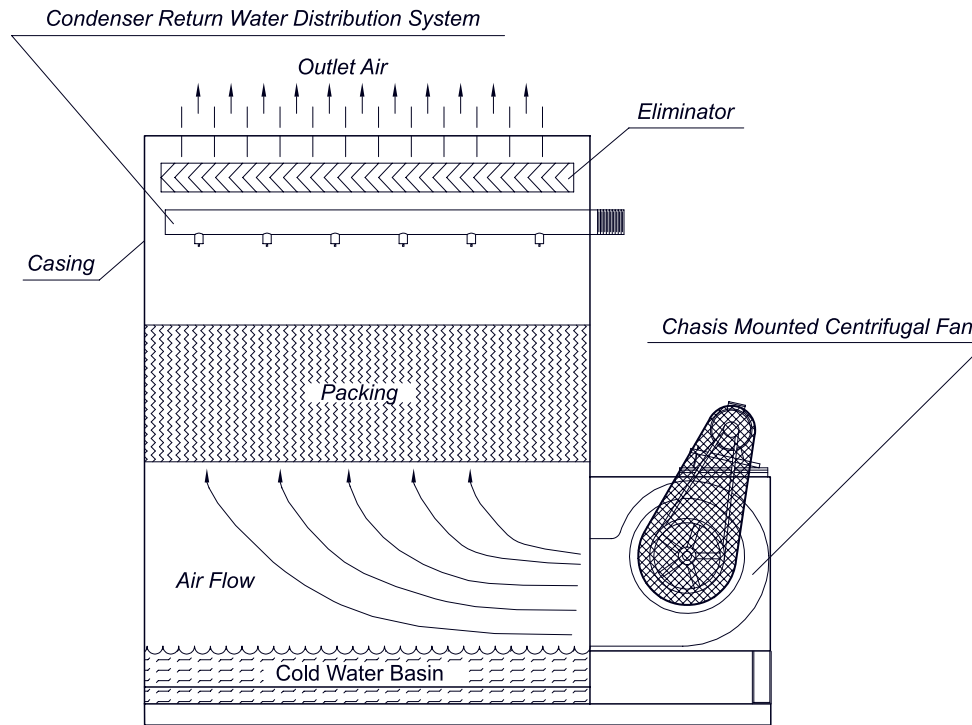

Main Features

Casing:

Rigidly constructed structure made from galvanized steel sheets to enclose all integral parts except the fan section. Blowers have their own housings.

Water Basin:

This section includes water outlet, quick fill and drain connections. The Basin is made from heavy gauge galvanized steel sheets.

Motors:

All electrical motors employed in Saran galvanized cooling towers are squirrel cage with degree of protection of IP-54 and insulation class F. All motors are 380V-3Ø-50Hz and operate at 1450 RPM and selected to match the horsepower requirements of the fans.

Fans:

Double inlet forward curved centrifugal fans, statically and dynamically balanced offering smooth running and quite operation. Blower and fan housing are made from galvanized steel sheets. All fan shafts are made of carbon steel and are precision machined to provide an accurate fit with the fan bearings and the wheel hub.

Packing (Cooling Surfaces):

The heat transfer surface in Saran galvanized cooling towers are splash type, Non-Clogging fills fabricated of PVC. The unique design of the fill with optimum 3-dimentional flow through the fill promotes greater air to water contact over other types of designs and are more effective with in the same amount of space, air flow and GPM with really inconsiderable pressure drop.

The durability against blockage, non-corrosive material and ease of service and replacement are the benefits of this type of fill.

Water Distribution System:

For spread of water entering the cooling tower as evenly as possible over the cooling surfaces, banks of non-clogging nozzles are used to spray the water.

Drift Eliminators:

They are positioned in the outlet air stream above the water distribution system in order to prevent water droplets from being carried away from the tower by the air stream. Eliminator baffles are made of galvanized steel sheets.



Blower Fan



Packing (PVC) for Cooling Tower

Selection Procedure

Nominal Saran galvanized cooling tower capacity (TR) presented in the "Technical Data" tables defined as cooling 3 GPM water flow rate with 10°F range and 10°F approach at 87°F entering wet-bulb temperature. So following formula can use for determining required cooling capacity of cooling tower:

$$\text{Required Cooling Tower Capacity (TR)} = \text{CF} \times \text{Water Flow Rate (GPM)} / 3$$

Where CF denotes correction factor of tower's cooling capacity in nonstandard conditions and denoted in correction factor curves. For range less than 15°F single stage cooling tower are selected by applying correction factor from figure 1 and for range of greater than 15°F, double stage cooling tower are selected by applying suitable correction factor from figure 2.

EWT: Entering Water Temperature (°F)

LWT: Leaving Water Temperature (°F)

EAT: Entering Air Wet Bulb Temperature (°F)

Example 1: Single Stage Cooling Tower Selection

Given:

Design flow rate: 300 GPM

EWT: 95°F

LWT: 85°F

EAT: 75°F

Selection Procedure:

According to above procedure, we have:

$$\text{Range} = \text{EWT} - \text{LWT} = 95^\circ\text{F} - 85^\circ\text{F} = 10^\circ\text{F}$$

$$\text{Approach} = \text{LWT} - \text{EAT} = 85^\circ\text{F} - 75^\circ\text{F} = 10^\circ\text{F}$$

For correction factor determining, refer to figure 1 at 10°F range and follow the horizontal line to the intersection of the 10°F approach curve. Proceed vertically downward to intersect the design 75°F wet bulb curve. Next, proceed horizontally left to find the correction factor (in this problem correction factor is 1.33).

So our required cooling capacity in this problem will be:

$$\text{Required Cooling Tower Capacity (TR)} = \text{CF} \times \text{Water Flow Rate (GPM)} / 3 = 1.33 \times 300 / 3 = 133 \text{ TR}$$

So by referring to table 1, we can see cooling capacity of 1SRCT-140S satisfy our requirements.

Example 2: Double Stage Cooling Tower Selection

Given:

Design flow rate: 300 GPM

EWT: 105°F

LWT: 85°F

EAT: 70°F

Selection Procedure:

According to above procedure, we have:

$$\text{Range} = \text{EWT} - \text{LWT} = 105^\circ\text{F} - 85^\circ\text{F} = 20^\circ\text{F}$$

$$\text{Approach} = \text{LWT} - \text{EAT} = 85^\circ\text{F} - 70^\circ\text{F} = 15^\circ\text{F}$$

Because of our range is over than 15°F, for correction factor determining, refer to figure 2 at 20°F range and follow the horizontal line to the intersection of the 15°F approach curve. Proceed vertically downward to intersect the design 70°F wet bulb curve. Next, proceed horizontally left to find the correction factor (in this problem correction factor is 1.00).

So our required cooling capacity in this problem will be:

$$\text{Required Cooling Tower Capacity (TR)} = \text{CF} \times \text{Water Flow Rate (GPM)} / 3 = 1.00 \times 480 / 3 = 160 \text{ TR}$$

So by referring to table 3, we can see cooling capacity of 2SRCT-160D satisfy our requirements.

Correction Factors Graph

Figure 1 - Correction Factor for Single Stage Cooling Tower

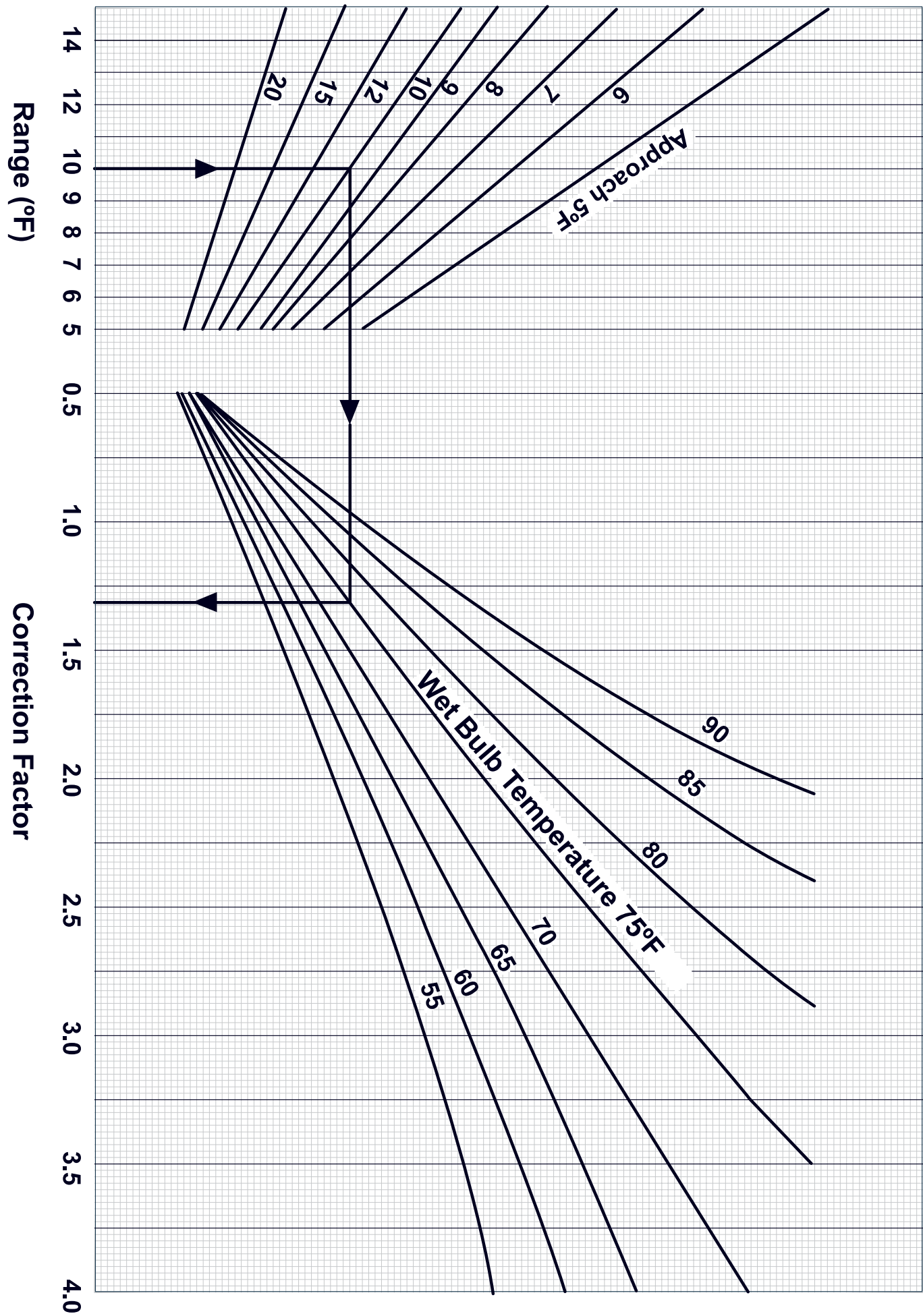

Correction Factors Graph

Figure 2 - Correction Factor for Double Stages Cooling Tower

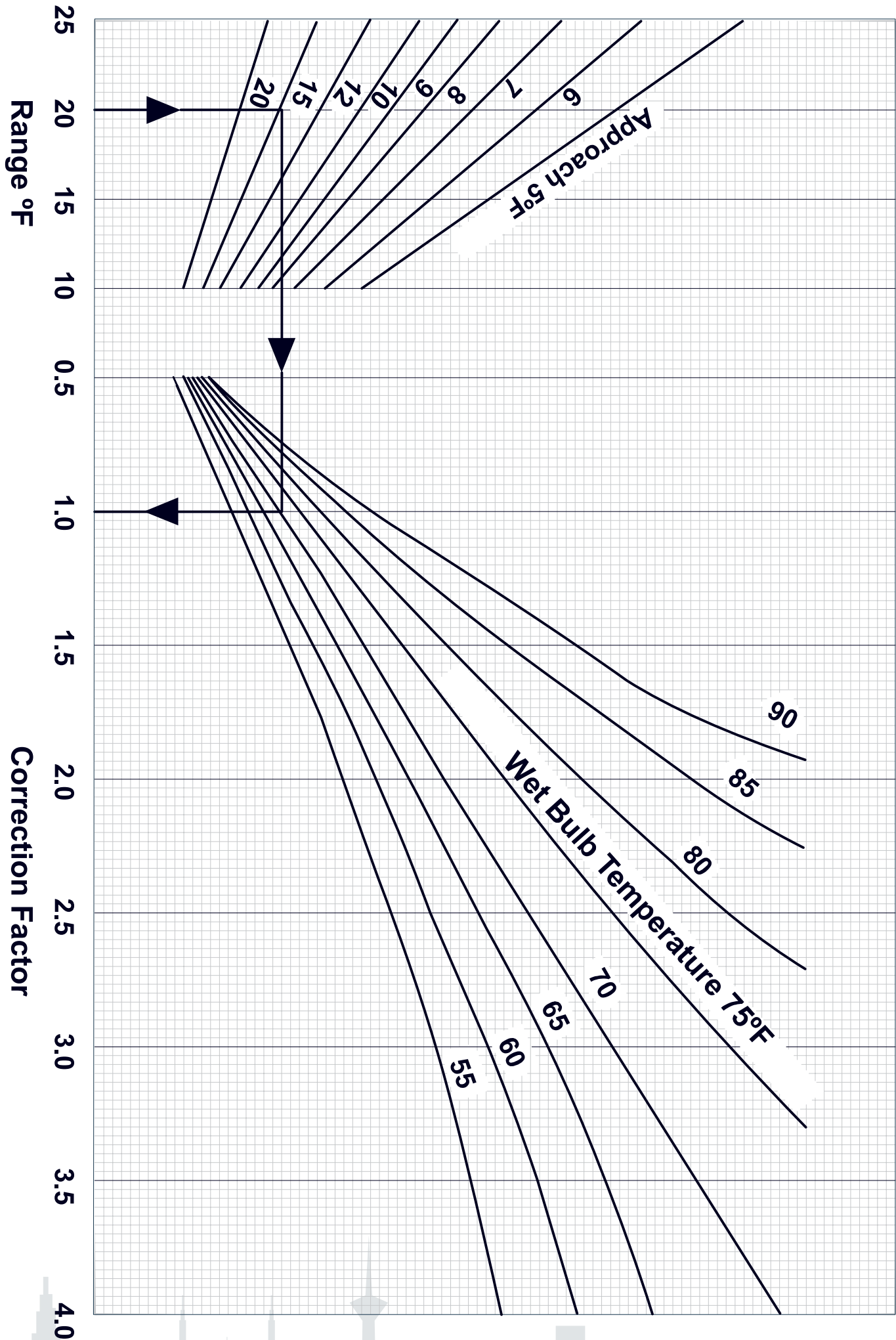

Models with Blowers on One Side

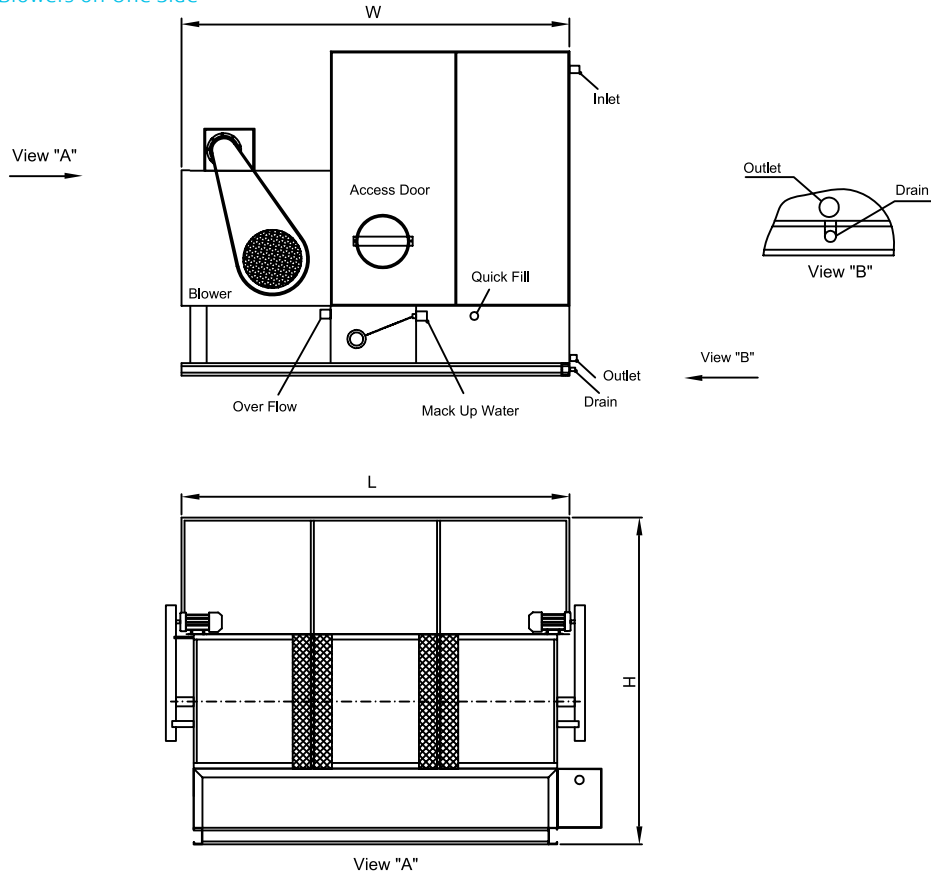

NOTE

- In model 1SRCT-300 make up water basins are on both sides.
- In model 60 tons and below, the make up water basin is omitted.

Models with Blowers on Two Sides

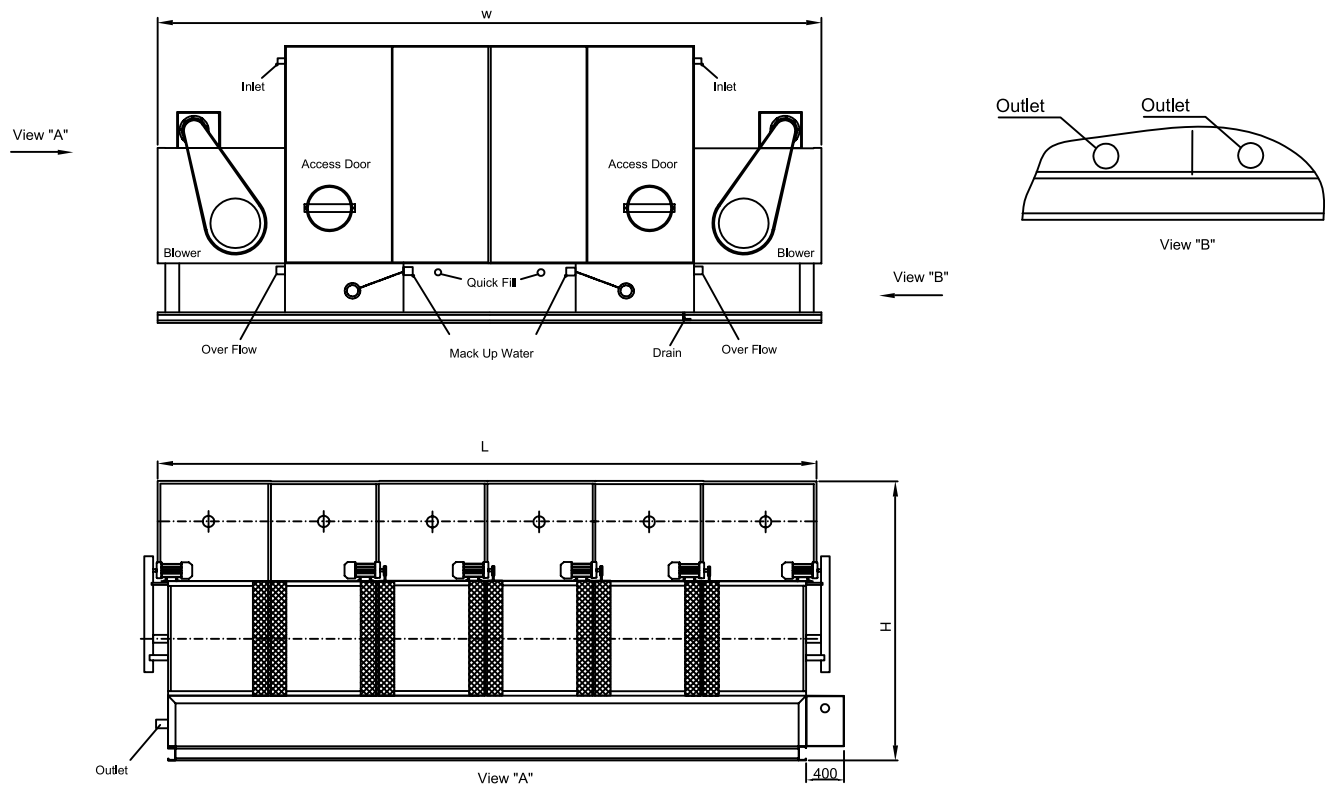

NOTE

- In model 2SRCT-580 to 1140 make up water basins are on both sides.

Technical Data

Table 1: Technical Data (Cooling Towers with Blower on One Side)

Model	Cap. (Tons)	Water Flow Rate (GPM)	Blower						Electrical Data			Weight (kg)			
			No.	Dia. (Inch)	Motor (1)		Motor (2)		System kW Input	Total Amp.	Wire Size	Single Stage		Double Stages	
					No.	Output (HP)	No.	Output (HP)				Net	Oper.	Net	Oper.
1SRCT 10	10	30	1	13"	1	1	-	-	0.75	2.3	4×1	330	420	370	460
1SRCT 15	15	45	1	17"	1	1.5	-	-	1.1	2.8	4×1	430	530	485	585
1SRCT 20	20	60	1	19"	1	2	-	-	1.5	4.0	4×1	475	645	545	715
1SRCT 25	25	75	1	19"	1	3	-	-	2.2	5.3	4×1.5	570	770	665	865
1SRCT 30	30	90	1	22"	1	3	-	-	2.2	5.3	4×1.5	665	1015	770	1120
1SRCT 35	35	105	1	22"	1	4	-	-	3.0	7.5	4×2.5	780	1210	910	1340
1SRCT 40	40	120	1	22"	1	5.5	-	-	4.0	8.8	4×2.5	830	1300	970	1440
1SRCT 50	50	150	1	22"	1	5.5	-	-	4.0	8.8	4×2.5	1000	1630	1180	1810
1SRCT 60	60	180	1	22"	1	5.5	-	-	4.0	8.8	4×2.5	1140	1940	1350	2150
1SRCT 75	75	225	2	22"	1	10	-	-	7.5	16.5	4×4	1425	2425	1680	2680
1SRCT 90	90	270	2	22"	1	10	-	-	7.5	16.5	4×4	1570	2720	1850	3000
1SRCT 105	105	315	2	22"	2	5.5	-	-	8.0	17.6	4×4	1665	3065	2010	3410
1SRCT 120	120	360	3	22"	1	10	1	5.5	11.5	25.3	4×6	2375	4025	2790	4440
1SRCT 140	140	420	3	22"	1	10	1	5.5	11.5	25.3	4×6	2850	4850	3330	5330
1SRCT 160	160	480	4	22"	2	10	-	-	15.0	33.0	4×10	3325	5625	3875	6175
1SRCT 180	180	540	4	22"	2	10	-	-	15.0	33.0	4×10	3375	5675	3955	6255
1SRCT 220	220	660	5	22"	5	5.5	-	-	20.0	44.0	4×16	3390	6790	3700	7500
1SRCT 260	260	780	6	22"	6	5.5	-	-	24.0	52.8	3×25/16	4750	8250	5565	9065
1SRCT 300	300	900	7	22"	7	5.5	-	-	28.0	61.6	3×25/16	5320	9220	6300	10200

NOTE

- Wire sizes given are max. Length, of 70m and maximum ambient temperature of 40°C.

Table 2: Dimension & Connections (Cooling Towers with Blower on One Side)

Model	Dimensions (mm)			Connection											
	L	W	H	Inlet		Outlet		Make Up		Over Flow		Quick Fill		Drain	
				No.	Dia.	No.	Dia.	No.	Dia.	No.	Dia.	No.	Dia.	No.	Dia.
1SRCT 10	550	1500	2000	1	1 1/2"	1	1 1/2"	1	1/2"	1	2"	1	1/2"	1	3/4"
1SRCT 15	720	1690	2000	1	1 1/2"	1	1 1/2"	1	1/2"	1	2"	1	1/2"	1	3/4"
1SRCT 20	1000	1720	2000	1	2"	1	2"	1	1/2"	1	2"	1	1/2"	1	3/4"
1SRCT 25	1000	2020	2000	1	2"	1	2"	1	1/2"	1	2"	1	1/2"	1	3/4"
1SRCT 30	1000	2360	2000	1	3"	1	3"	1	3/4"	1	2"	1	3/4"	1	3/4"
1SRCT 35	1000	2660	2000	1	3"	1	3"	1	3/4"	1	2"	1	3/4"	1	3/4"
1SRCT 40	1000	2860	2000	1	3"	1	3"	1	3/4"	1	2"	1	3/4"	1	3/4"
1SRCT 50	1250	2860	2000	1	3"	1	3"	1	3/4"	1	2"	1	3/4"	1	3/4"
1SRCT 60	1450	2860	2690	1	4"	1	4"	1	3/4"	1	2"	1	3/4"	2	3/4"
1SRCT 75	1750	2860	2690	2	3"	1	4"	1	1"	1	2"	1	1"	3	3/4"
1SRCT 90	1950	2860	2690	2	3"	1	4"	1	1"	1	2"	1	1"	3	3/4"
1SRCT 105	2400	2860	2690	3	3"	1	4"	1	1"	1	2"	1	1"	4	3/4"
1SRCT 120	2900	2860	2690	3	3"	1	5"	1	1"	2	2"	1	1"	2	3/4"
1SRCT 140	3350	2860	2690	4	3"	1	5"	1	1"	2	2"	1	1"	5	3/4"
1SRCT 160	3850	2860	2690	4	3"	2	4"	1	1"	2	2"	1	1"	5	3/4"
1SRCT 180	4080	2860	2690	5	3"	2	4"	1	1"	2	2"	1	1"	6	3/4"
1SRCT 220	4800	2860	2690	5	3"	3	4"	1	1"	2	2"	1	1"	6	3/4"
1SRCT 260	5750	2860	2690	6	3"	3	4"	1	1"	2	2"	1	1"	7	3/4"
1SRCT 300	6700	2860	2690	7	3"	3	5"	2	1"	2	2"	2	1"	9	3/4"

NOTE

- Add 300 mm to "H" for additional stage.
- All entries subject to change without notice.



Technical Data (Cont.)

Table 3: Technical Data (Cooling Towers with Blower on One Side)

Model	Cap. (Tons)	Water Flow Rate (GPM)	Blower						Electrical Data			Weight (KG)			
			No.	Dia. (Inch)	Motor (1)		Motor (2)		System KW Input	Total Amp.	Wire Size	Single Stage		Double Stages	
					No.	Output (HP)	No.	Output (HP)				Net	Oper.	Net	Oper.
2SRCT 340	340	1020	8	22"	8	5.5	-	-	32	70.4	3*25/16	6175	10675	7255	11755
2SRCT 400	400	1200	10	22"	10	5.5	-	-	40	88	3*35/16	6650	12150	8000	13500
2SRCT 450	450	1350	12	22"	12	5.5	-	-	48	105.6	3*50/25	8550	15350	10115	16915
2SRCT 500	500	1500	12	22"	12	5.5	-	-	48	105.6	3*50/25	8550	15350	10115	16915
2SRCT 580	580	1740	14	22"	14	5.5	-	-	56	123.2	3*70/35	9500	17000	11365	18865
2SRCT 660	660	1980	16	22"	16	5.5	-	-	64	140.8	3*95/50	11875	20875	14010	23010
2SRCT 740	740	2220	18	22"	18	5.5	-	-	72	158.4	3*95/50	13300	23300	15690	25690
2SRCT 820	820	2460	20	22"	20	5.5	-	-	80	176	3*120/70	14725	25725	17385	28385
2SRCT 900	900	2700	22	22"	22	5.5	-	-	88	193.6	3*150/70	16150	28650	19065	31565
2SRCT 980	980	2940	24	22"	24	5.5	-	-	96	211.2	3*150/70	16625	30125	19800	33300
2SRCT 1060	1060	3180	26	22"	26	5.5	-	-	104	228.8	3*185/95	19000	34000	22445	37445
2SRCT 1140	1140	3420	28	22"	28	5.5	-	-	112	264.4	3*185/95	20900	36400	24600	40100

NOTE

- Two 5.5 HP electric motors can be installed in place of 10 HP electric motor when required.
- Wire sizes given are max. Length of 50 m and maximum ambient temperature of 50°C.
- Consider 23 feet of nozzle head per unit listed.

Table 4: Dimension & Connections (Cooling Towers with Blower on Both Sides)

Model	Dimensions (mm)			Connection											
	L	W	H	Inlet		Outlet		Make Up		Over Flow		Quick Fill		Drain	
				No.	Dia.	No.	Dia.	No.	Dia.	No.	Dia.	No.	Dia.	No.	Dia.
2SRCT 340	3850	5680	2690	8	3"	4	5"	2"	1"	2	2"	2	1"	10	3/4"
2SRCT 400	4800	5680	2690	10	3"	4	5"	2"	1"	2	2"	2	1"	12	3/4"
2SRCT 450	5750	5680	2690	12	3"	4	5"	2"	1"	2	2"	2	1"	14	3/4"
2SRCT 500	5750	5680	2690	12	3"	4	5"	2"	1"	2	2"	2	1"	14	3/4"
2SRCT 580	6700	5680	2690	14	3"	4	5"	2"	1"	2	2"	2	1"	16	3/4"
2SRCT 660	7650	5680	2690	16	3"	4	5"	2"	1"	2	2"	2	1"	18	3/4"

NOTE

- Add 300 mm to "H" for additional stage.
- All entries subject to change without notice.

Service Area

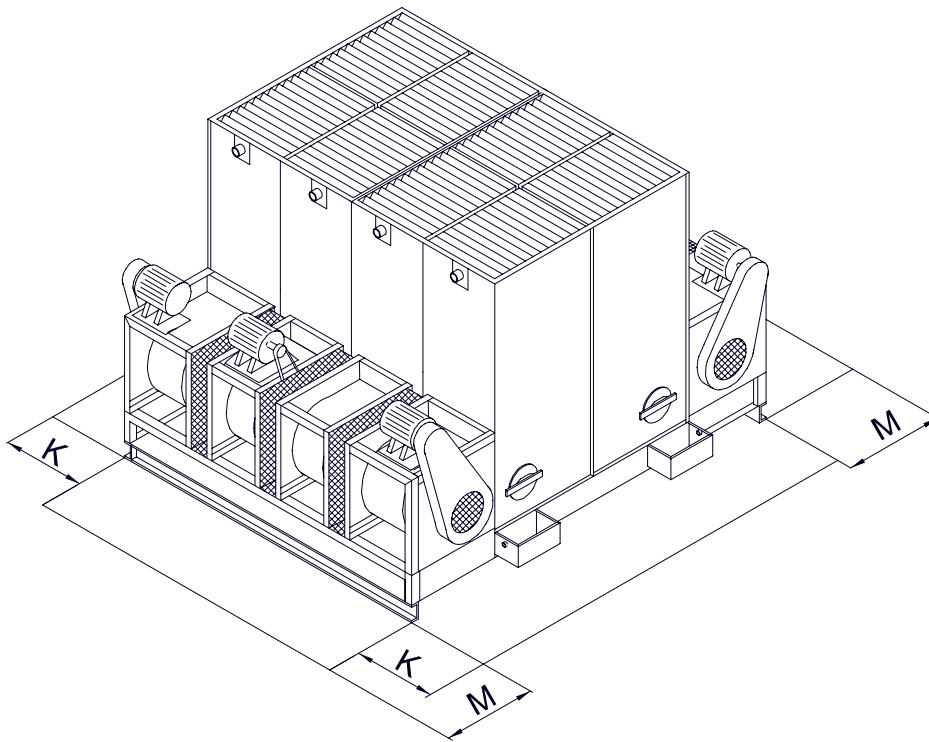
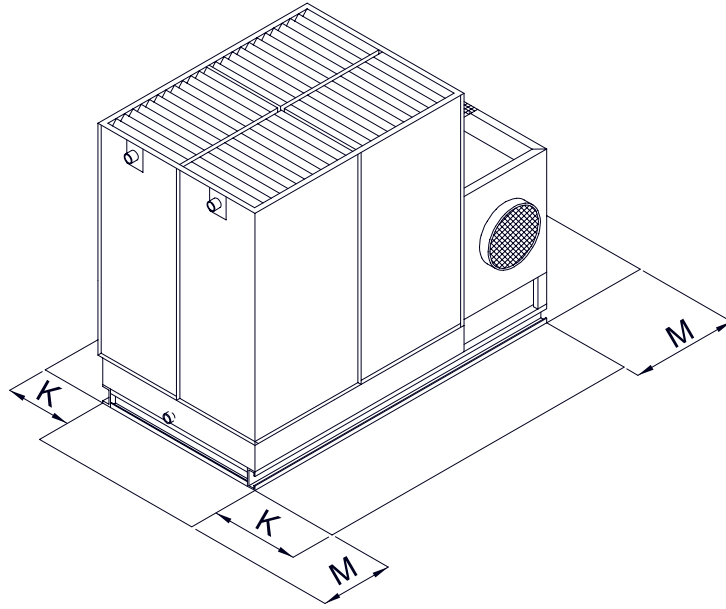

Model	K	M
1SRCT-10 ~ 1SRCT-60	1500	1500
1SRCT-75 ~ 1SRCT-300	2500	2000
2SRCT-340 ~ 2SRCT-1140	2500	2000

NOTE

- All dimensions are in mm.