



www.saran-mfg.com saran@saran-mfg.com



MINI CHILLER

Saran

Life's Pleasant Breeze

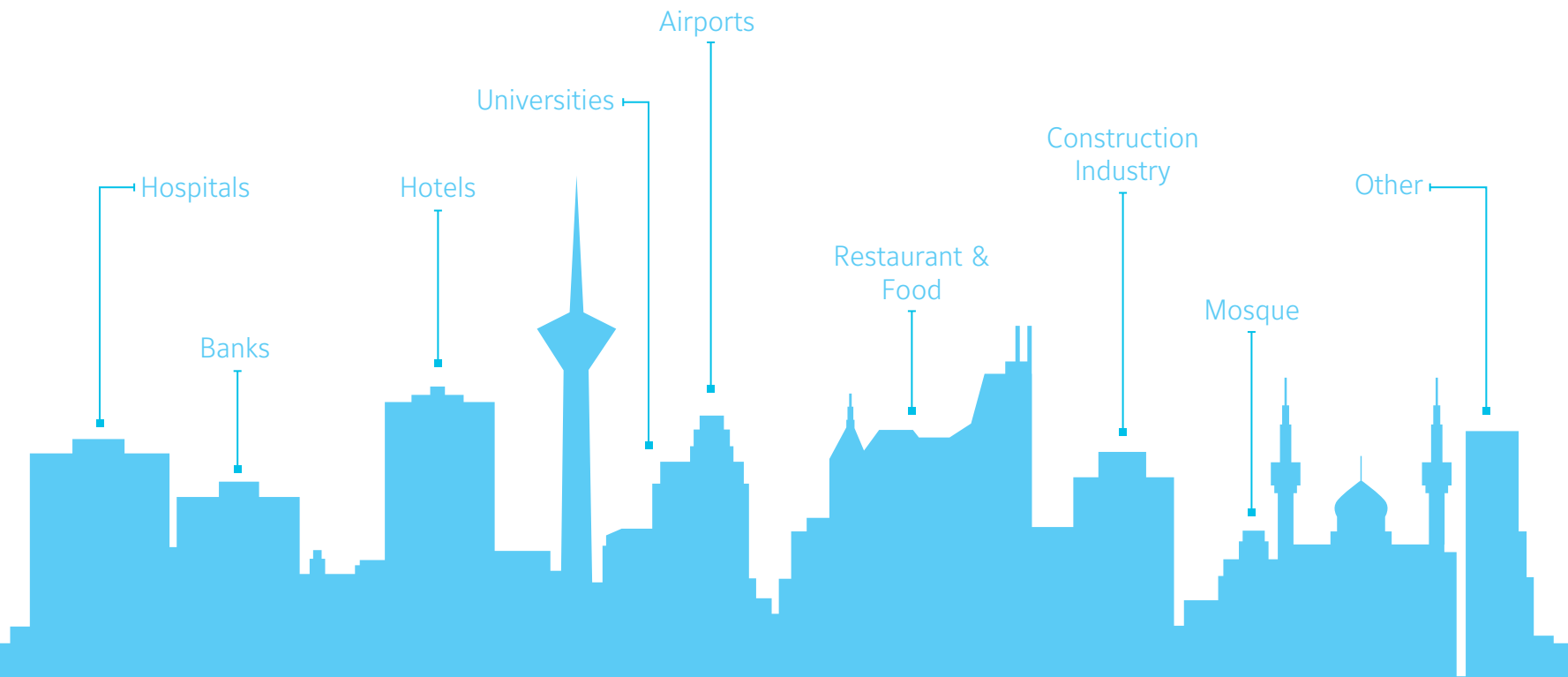

AIR CONDITIONING MFG.GROUP

www.saran-mfg.com
saran@saran-mfg.com



Contents

Nomenclature	4
Introduction	5
Selection Information	6
Select Example	7
Technical Data	8
Performance Data	9
Flow Rate-Pressure Drop Graph	13
Electrical Data	13
Installation	14
Dimensions	15



NOMENCLATURE

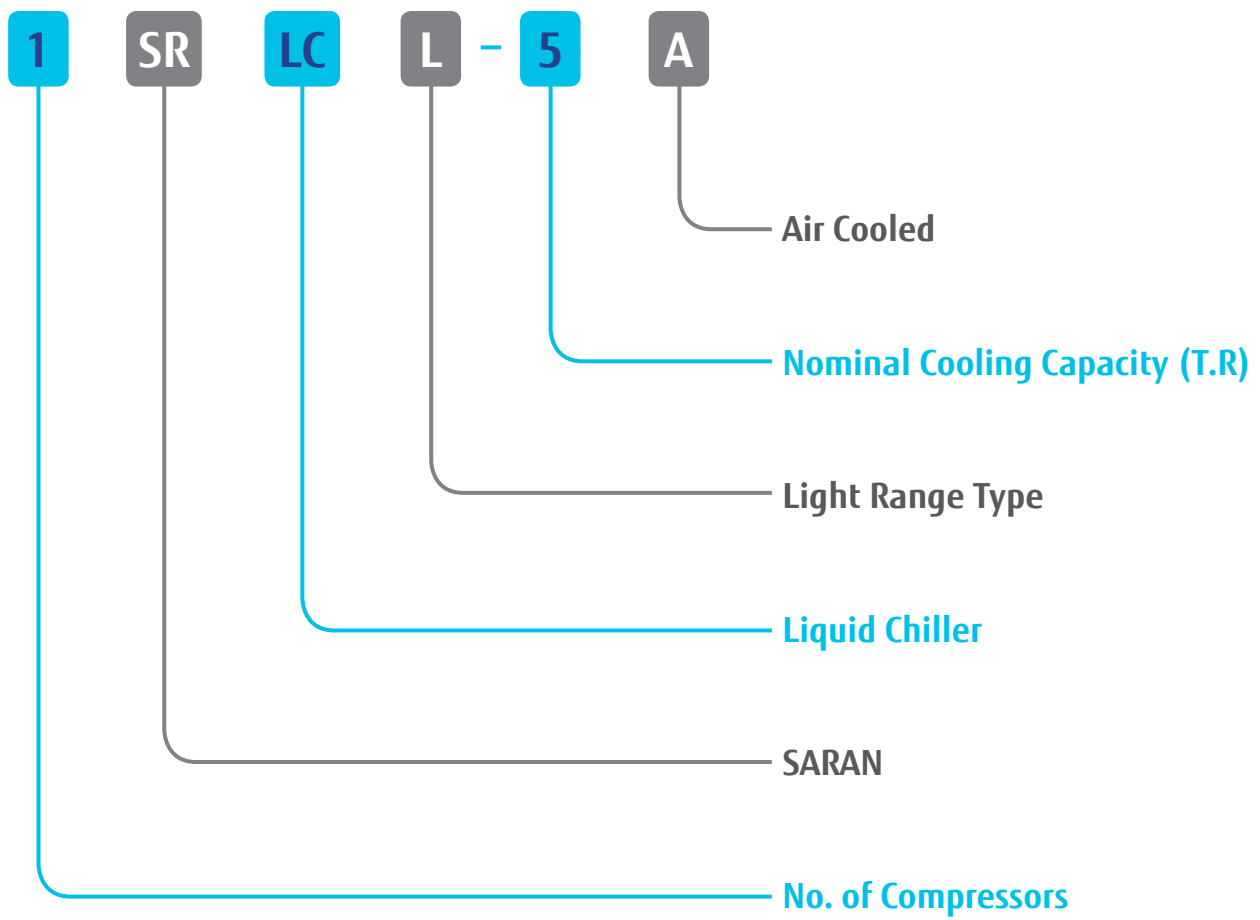



Introduction

Saran mini chillers are a new innovative concept in residential and industrial applications. Saran mini chillers are available in nominal cooling capacity of 3, 5, 7.5 and 10 tons of refrigeration with availability of many accessories, including advanced control and safety devices.

Main Component Features

Compressor:

Saran mini chillers are equipped with highly efficient, reliable and silent scroll compressor. The compressor adopts hermetic type to further eliminate operating noise and vibration.

Evaporator:

Saran mini chillers are equipped with the brazed plate heat exchanger (BPHE) from world-renowned brands. BPHE represents the cutting edge of heat exchanger technology and its one of the most effective and efficient thermal transfer solutions. Extremely compact design, reduced refrigerant charge, small temperature difference, true counter flow and self-cleaning features of BPHEs obtain Saran mini chillers more efficient and reliable.

Condenser:

The condenser coils are made of staggered rows of 3/8 inches diameter seamless inner grooved copper tube, mechanically expanded into slit aluminum fins to ensure optimum heat exchange capability. The fins have full spacing collars which completely cover each tube. The staggered tube design improves the thermal efficiency of the coil and eliminates bypassing of air around the tubes. A separate sub cooling circuit is standard on all units to maximize energy efficiency. The condenser coils are designed and constructed base on AHRI standards and equipped with suitable low noise axial fans from well-known international brands.

Refrigerant:

Saran mini chillers can be design to operate with R-22, R-407C and R-134a refrigerants, so these units can operating more efficient in wide range of ambient conditions. (In the tropical conditions is suggested to use R-134a).

Circulation Pump:

All models of Saran mini chillers equipped with high efficient centrifugal pump which applied sufficient chilled water flow rate in high-pressure drop of customer's piping line.

Additional Safety Protection:

Saran mini chillers are equipped with intelligently designed safety control to ensure continuous safe operation. High and low pressure switch is provided to prevent the compressor damage resulting from both abnormal high discharge head pressure and low pressure due to insufficient gas. In addition, thermal and current overload protector are supplied with the units as well as phase sequencer protector.

Flow switch is provided in the unit to protect against damage to the water pump. The standard mechanical controller provides accurate water temperature control in the circuit by closely monitoring and reacting to the input from the water entering temperature, water leaving temperature and ambient air temperature.

Factory Testing:

Each unit is pressure tested, vacuum tested, evacuated and charged with refrigerant requested then It tested at the factory's test bench under the design conditions specified by the customer. Before shipment, each unit is recheck for pressure and refrigerant charge control.

Selection Information

Cooling capacity of Saran mini chillers presented in the "Performance Data" tables; cover the most frequently encountered leaving water temperatures.

The mini chillers are rated over a range of leaving water temperatures of 42°F to 46°F and ambient temperatures of 95°F to 120°F.

To select a Saran mini chiller, the following information is required:

1. Design system load (Btu/h)
2. Design leaving water temperature (°F)
3. Design chilled water range (°F)
4. Evaporator fouling factor (h.ft².°F/Btu)
5. Design ambient temperature (°F)
6. Altitude (ft)

Chilled Water Flow and Range:

Required cooling capacity and the desired chilled water range are two important factors in determining the amount of water to be circulate in the evaporator. The following formula used for determining chilled water flow:

$$\text{Chilled Water Flow (GPM)} = \frac{24 \times \text{Cooling Capacity (TR)}}{\text{Chilled Water Range (°F)}}$$

Performance tables in this catalogue are based on a 10°F temperature drop through the evaporator. In other conditions please using following correction factors for cooling capacities:

Table 1: Chilled Water Range Correction Factors

Chilled Water Range (°F)	Correction Factor
6	0.992
8	0.995
10	1.000
12	1.005
14	1.010
16	1.014

Fouling Factor:

The cooling capacity of the mini chillers in this catalogue permit a fouling factor of 0.0001 h.ft².°F/Btu (ARI Standard 550/590-98) for the evaporators. In other conditions please using following correction factors for performance data:

Table 2: Fouling Factor Correction Factors

Fouling factor (h.ft ² .°F /Btu)	Correction Factor
0.00010	1
0.00025	0.992
0.00050	0.978
0.00075	0.965
0.00100	0.951

Altitude:

Performance tables of the mini chillers in this catalogue are based on sea level altitude, so in other conditions, please using following correction factors for performance data:

Table 3: Altitude Correction Factor

Altitude (ft)	Correction Factor
0	1.00
2000	0.99
4000	0.98
6000	0.96



Selection Example:

Given:

Chilled water flow rate = 9 GPM

Design chilled water range = 10°F

Evaporator leaving water temperature = 45°F

Ambient temperature = 105°F

Evaporator fouling factor = 0.0001 h.ft².°F/Btu

Altitude = sea level

Refrigerant = R407C

Solution:

Step 1: Cooling capacity calculation

To calculate the required cooling capacity we use the following formula:

Cooling Capacity (TR) = Chilled Water Flow (GPM) x Chilled Water Range (°F) / 24;

So in this problem, our required cooling capacity is 3.8 TR (45 MBH);

Step 2: Mini chiller model selection

By referring to the performance data table of mini chillers, we can see cooling capacity of 1SRLCL-5A in ambient temperature of 105°F and evaporator leaving water temperature of 45°F is 45.7 MBH. So, cooling capacity of 1SRLCL-5A satisfy our requirements.

Step 3: Maximum chiller's pump head calculation

By referring to Saran mini chiller pump head pressure graph, we can find selected mini chiller's maximum satisfied pressure drop.

Technical Data

Table 4: Technical Data

Models	1SRLCL-3A	1SRLCL-5A	1SRLCL-7.5A	1SRLCL-10A	
Actual Cooling Capacity (MBH)	32.8	48.6	78.4	104.5	
Actual Power Input (kW)	4.00	5.31	8.02	9.97	
Compressor					
Type	Hermetic Scroll				
Capacity Control	Fixed Speed				
Quantity	1	1	1	1	
Evaporator					
Type	Braze Plate Heat Exchanger (BPHE)				
Water Connector (inches)	1"	1 1/4"	1 1/2"	1 1/2"	
Water Flow Rate (GPM)	6.6	9.7	15.7	20.9	
Condenser					
Coil Rows Deep	2	3	3	4	
Total Coils Face Area (Sq. ft)	7.8	7.8	11.4	12.1	
Total Air Flow (CFM)	5500	5000	7000	6600	
Fan Quantity	1	1	2	2	
Fan Diameter (inches)	25	25	20	20	
Fan Power Inputs (kW)	0.55	0.55	0.41	0.41	
Circulation Pump					
Type	Centrifugal				
Head (ft)	52.8	50.5	51.5	50.6	
Pump Power Input (kW)	0.59	0.59	0.73	0.73	
Refrigerant					
Standard (Optional)	R22 (R407C , R134a)				
Flow Control	Thermal Expansion Valve				
Number Of Circuits	1	1	1	1	
Refrigerant Charge (kg)	3.8	4.6	8.9	12.0	
Electrical Data					
Power Supply	230V/1 ϕ /50Hz	380V/3 ϕ /50Hz	380V/3 ϕ /50Hz	380V/3 ϕ /50Hz	380V/3 ϕ /50Hz
Maximum Power Input (kW)	5.11	5.19	6.14	9.5	12.05
Maximum Current (A)	24.5	11.25	13.2	20.7	24.2
Overall Dimensions					
Length (mm)	1250	1250	1250	1250	
Width (mm)	780	780	740	740	
Height (mm)	1020	1020	1365	1365	
Unit Weight					
Net Weight (kg)	385	410	480	520	
Operating Weight (kg)	400	430	505	550	

NOTE

- 1MBH = 1000 Btu/hr- Actual cooling capacities are based on entering / leaving water temperature of 56 °F / 46 °F , ambient temperature of 100 °F and R22.
- The above data is subject to change without notice.



Performance Data

Table 5: Performance Data (1SRLCL-3A)

Cooling Capacity (MBH)						
Refrigerant: R-22	Ambient Temperature					
LWT (°F)	95 °F	100 °F	105 °F	110 °F	115 °F	120 °F
42 °F	31.2	30.3	29.4	28.4	-	-
43 °F	31.8	30.9	30.0	29.0	-	-
44 °F	32.5	31.5	30.6	29.6	-	-
45 °F	33.1	32.2	31.2	30.2	-	-
46 °F	33.8	32.8	31.9	30.9	-	-

Cooling Capacity (MBH)						
Refrigerant: R-407C	Ambient Temperature					
LWT (°F)	95 °F	100 °F	105 °F	110 °F	115 °F	120 °F
42 °F	29.3	28.3	27.2	26.0	-	-
43 °F	30.0	28.9	27.8	26.7	-	-
44 °F	30.7	29.6	28.5	27.3	-	-
45 °F	31.4	30.3	29.1	27.9	-	-
46 °F	32.1	31.0	29.8	28.6	-	-

Cooling Capacity (MBH)						
Refrigerant: R-134a	Ambient Temperature					
LWT (°F)	95 °F	100 °F	105 °F	110 °F	115 °F	120 °F
42 °F	20.8	20.2	19.6	18.9	18.3	17.6
43 °F	21.3	20.7	20.0	19.4	18.7	18.0
44 °F	21.8	21.2	20.5	19.9	19.2	18.5
45 °F	22.3	21.7	21.0	20.3	19.6	18.9
46 °F	22.8	22.1	21.5	20.8	20.1	19.4

NOTE

- 1MBH = 1000 Btu/hr
- LWT = Leaving Water Temperature
- Cooling capacities are based on chilled water range of 10 °F and sea level altitude.
- The above data is subject to change without notice.



Performance Data (Cont.)

Table 6: Performance Data (1SRCL-5A)

Cooling Capacity (MBH)						
Refrigerant: R-22	Ambient Temperature					
LWT (°F)	95 °F	100 °F	105 °F	110 °F	115 °F	120 °F
42 °F	46.2	44.7	43.3	41.8	-	-
43 °F	47.2	45.7	44.2	42.8	-	-
44 °F	48.2	46.7	45.2	43.7	-	-
45 °F	49.2	47.6	46.1	44.6	-	-
46 °F	50.2	48.6	47.1	45.6	-	-

Cooling Capacity (MBH)						
Refrigerant: R-407C	Ambient Temperature					
LWT (°F)	95 °F	100 °F	105 °F	110 °F	115 °F	120 °F
42 °F	45.9	44.5	43.0	41.5	-	-
43 °F	46.8	45.4	43.9	42.4	-	-
44 °F	47.8	46.3	44.8	43.3	-	-
45 °F	48.7	47.2	45.7	44.1	-	-
46 °F	49.7	48.2	46.6	45.0	-	-

Cooling Capacity (MBH)						
Refrigerant: R-134a	Ambient Temperature					
LWT (°F)	95 °F	100 °F	105 °F	110 °F	115 °F	120 °F
42 °F	32.3	31.4	30.4	29.5	28.5	27.5
43 °F	33.1	32.1	31.1	30.2	29.1	28.1
44 °F	33.8	32.9	31.9	30.8	29.8	28.8
45 °F	34.6	33.6	32.6	31.6	30.5	29.4
46 °F	35.4	34.4	33.6	32.3	31.2	30.1

NOTE

- 1MBH = 1000 Btu/hr
- LWT = Leaving Water Temperature
- Cooling capacities are based on chilled water range of 10 °F and sea level altitude.
- The above data is subject to change without notice.



Performance Data (Cont.)

Table 7: Performance Data (1SRCL-7.5A)

Cooling Capacity (MBH)						
Refrigerant: R-22	Ambient Temperature					
LWT (°F)	95 °F	100 °F	105 °F	110 °F	115 °F	120 °F
42 °F	74.4	72.1	69.7	67.1	-	-
43 °F	76.0	73.7	71.2	68.6	-	-
44 °F	77.6	75.2	72.7	70.1	-	-
45 °F	79.2	76.8	74.3	71.7	-	-
46 °F	80.8	78.4	75.9	73.2	-	-

Cooling Capacity (MBH)						
Refrigerant: R-407C	Ambient Temperature					
LWT (°F)	95 °F	100 °F	105 °F	110 °F	115 °F	120 °F
42 °F	73.7	71.1	68.4	65.4	-	-
43 °F	75.3	72.7	69.9	66.9	-	-
44 °F	77.0	74.3	71.5	68.5	-	-
45 °F	78.6	76.0	73.2	70.1	-	-
46 °F	80.3	77.6	74.8	71.7	-	-

Cooling Capacity (MBH)						
Refrigerant: R-134a	Ambient Temperature					
LWT (°F)	95 °F	100 °F	105 °F	110 °F	115 °F	120 °F
42 °F	49.7	48.0	46.1	44.2	42.2	40.1
43 °F	50.9	49.1	47.3	45.4	43.3	41.2
44 °F	52.1	50.3	48.5	46.5	44.5	42.4
45 °F	53.3	51.5	49.7	47.7	45.6	43.5
46 °F	54.5	52.7	50.9	48.9	46.8	44.7

NOTE

- 1MBH = 1000 Btu/hr
- LWT = Leaving Water Temperature
- Cooling capacities are based on chilled water range of 10 °F and sea level altitude.
- The above data is subject to change without notice.



Performance Data (Cont.)

Table 8: Performance Data (1SRCL-10A)

Cooling Capacity (MBH)						
Refrigerant: R-22	Ambient Temperature					
LWT (°F)	95 °F	100 °F	105 °F	110 °F	115 °F	120 °F
42 °F	99.3	96.6	93.7	-	-	-
43 °F	101.0	98.5	95.6	-	-	-
44 °F	103.0	100.5	97.5	-	-	-
45 °F	105.0	102.5	99.4	-	-	-
46 °F	107.0	104.5	101.5	-	-	-

Cooling Capacity (MBH)						
Refrigerant: R-407C	Ambient Temperature					
LWT (°F)	95 °F	100 °F	105 °F	110 °F	115 °F	120 °F
42 °F	96.4	93.1	89.6	-	-	-
43 °F	98.5	95.2	91.7	-	-	-
44 °F	100.5	97.3	93.7	-	-	-
45 °F	103.0	99.4	95.8	-	-	-
46 °F	105.0	101.5	98.0	-	-	-

Cooling Capacity (MBH)						
Refrigerant: R-134a	Ambient Temperature					
LWT (°F)	95 °F	100 °F	105 °F	110 °F	115 °F	120 °F
42 °F	66.8	64.8	62.8	60.7	58.5	-
43 °F	68.3	66.3	64.2	62.1	59.9	-
44 °F	69.8	67.8	65.7	63.5	61.3	-
45 °F	71.4	69.3	67.2	65.0	62.7	-
46 °F	73.0	70.9	68.7	66.5	64.2	-

NOTE

- 1MBH = 1000 Btu/hr
- LWT = Leaving Water Temperature
- Cooling capacities are based on chilled water range of 10 °F and sea level altitude.
- The above data is subject to change without notice.

Flow Rate - Pressure Drop Graph

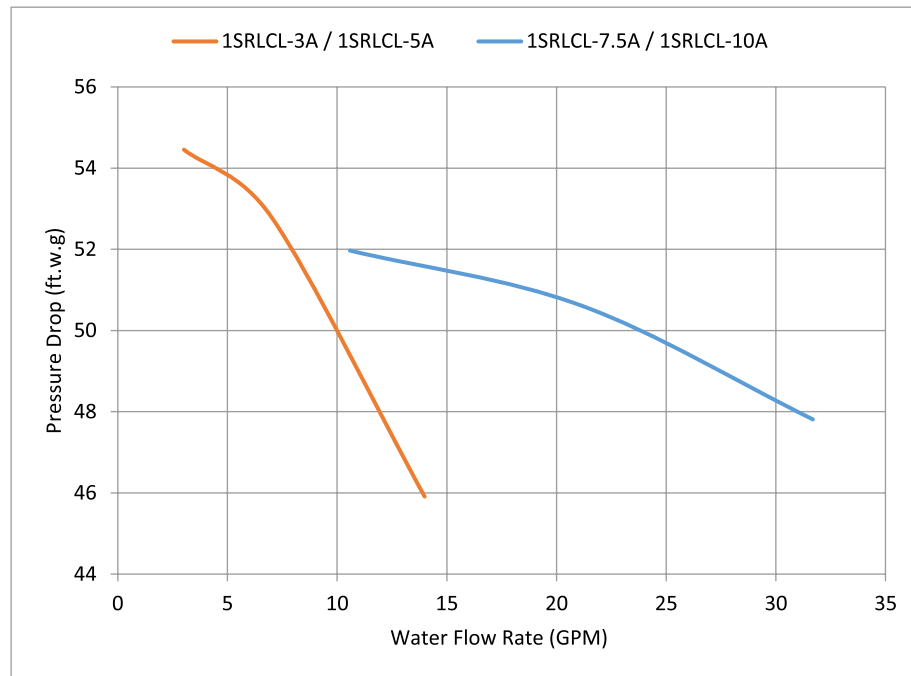

NOTE

- All above data subject to change without notice.

Electrical Data

Table 9: Electrical Data

Model	Refrigerant	Power Supply	Compressor						Fan(s)		Pump		Total Power			Cable Size (mm ²)
			Starting Type	RLA	FLA	MOC	LRA	MPI	MPI	FLA	MPI	FLA	RLA	FLA	MPI	
1SRLCL-3A	R22	220V/1 ϕ /50HZ	D.O.L	16.15	19.15	23.5	114	4.00	0.52	2.55	0.59	2.8	21.5	24.5	5.11	2x10
	R407C		D.O.L	16.35	19.50	23.5	114	4.10	0.52	2.55	0.59	2.8	21.7	24.85	5.21	2x10
	R134a		D.O.L	14.50	15.80	23.5	114	2.90	0.52	2.55	0.59	2.8	19.85	21.15	4.01	2x6
1SRLCL-3A	R22	380V/3 ϕ /50HZ	D.O.L	6.20	7.00	10.0	50	4.05	0.55	1.45	0.59	2.8	10.45	11.25	5.19	4x2.5
	R407C		D.O.L	6.25	7.05	10.0	50	4.00	0.55	1.45	0.59	2.8	10.5	11.3	5.14	4x2.5
	R134a		D.O.L	4.55	5.25	10.0	50	2.80	0.55	1.45	0.59	2.8	8.8	9.5	3.94	4x2.5
1SRLCL-5A	R22	380V/3 ϕ /50HZ	D.O.L	7.75	8.95	11.0	65.5	5.00	0.55	1.45	0.59	2.8	12	13.2	6.14	4x4
	R407C		D.O.L	7.05	8.30	12.0	59	5.00	0.55	1.45	0.59	2.8	11.3	12.55	6.14	4x4
	R134a		D.O.L	5.65	6.35	11.0	65.5	3.30	0.55	1.45	0.59	2.8	9.9	10.6	4.44	4x2.5
1SRLCL-7.5A	R22	380V/3 ϕ /50HZ	D.O.L	11.55	13.60	15.9	95	7.45	0.90	1.8	1.15	5.3	18.65	20.7	9.5	4x6
	R407C		D.O.L	12.00	13.70	15.9	95	7.65	0.90	1.8	1.15	5.3	19.1	20.8	9.7	4x6
	R134a		D.O.L	9.75	10.65	15.9	95	5.10	0.90	1.8	1.15	5.3	16.85	17.75	7.15	4x4
1SRLCL-10A	R22	380V/3 ϕ /50HZ	D.O.L	14.60	17.10	19.6	118	10.00	0.90	1.8	1.15	5.3	21.7	24.2	12.05	4x10
	R407C		D.O.L	14.80	17.35	19.6	118	9.95	0.90	1.8	1.15	5.3	21.9	24.45	12.0	4x10
	R134a		D.O.L	11.60	12.90	19.6	118	6.55	0.90	1.8	1.15	5.3	18.7	20	8.6	4x6

NOTE

- RLA: Rated Load Ampere
- FLA: Full Load Ampere
- MOC: Maximum Operating Current
- LRA: Lock Rotor Ampere
- MPI: Maximum Power Input (kW)
- D.O.L: Direct On Line Start Type
- Cable size are based on copper conductor at maximum ambient temperature of 40°C and maximum distance of 70 meter.
- All above data subject to change without notice.

Installation

Please read this chapter carefully before installation, and you must install the machine according to the following procedures. Install the chiller in places with good air flowing because air-cooled chiller needs a good heat releasing condition. If the chiller is installed inside the factory, then the surrounding temperature should not be higher than 105°F and there must have fans to make air flow fluently.

Installation Notice Items:

- 1- Make sure that voltage of electricity matches with the nameplate.
- 2- Connect the electricity wire and earth wire according to local regulations.
- 3- Use independent electricity wire and power switch. The diameter of the wire should not be less than of electric cabinet's wire.
- 4- The end of the electricity wire should be safe and firm.
- 5- Protect water chilling pipes with insulating materials.

Select Installation Site:

In order to achieve maximum cooling capacity, the location selection should fulfill the following requirements:

- 1- Install the chiller in such a way that the hot air discharge cannot be drawn in again
- 2- Ensure that there is no obstruction to air flow into or out of the unit. Remove obstacles which blocking intake or discharge air.
- 3- The location must be well ventilated, so air can be drawn in and discharge out efficiently.
- 4- Choose a place which can rigidly support the weight of the unit, this will help to minimize vibration and noise.
- 5- The location must not be susceptible to dust or oil to avoid condenser coil being choke by the contaminant. As the general safety precaution, it is advised that no flammable danger gas should be located near to the unit.
- 6- Water source of the cooler must be clean and free from any contaminant such as rusted particles or any kind of oil. It is necessary to install a water filter in the returning water line.
- 7- Set apart some service space. Space ranges are recommended in following schematics:

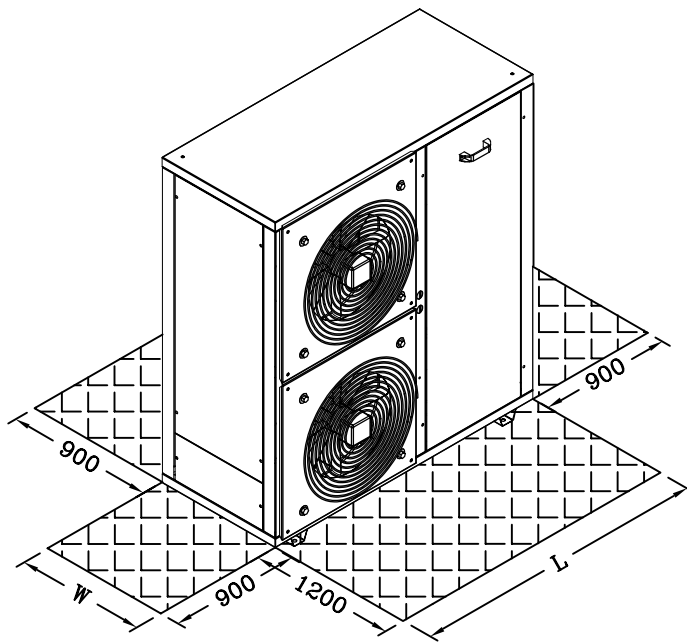

NOTE

- L: Chiller Length
- W: Chiller Width
- All dimensions are in millimeter.

8- In order to achieve best air intake in the unit and easy maintenance, unit's access door, electrical panel and coils sides should be considered base on following scheme:

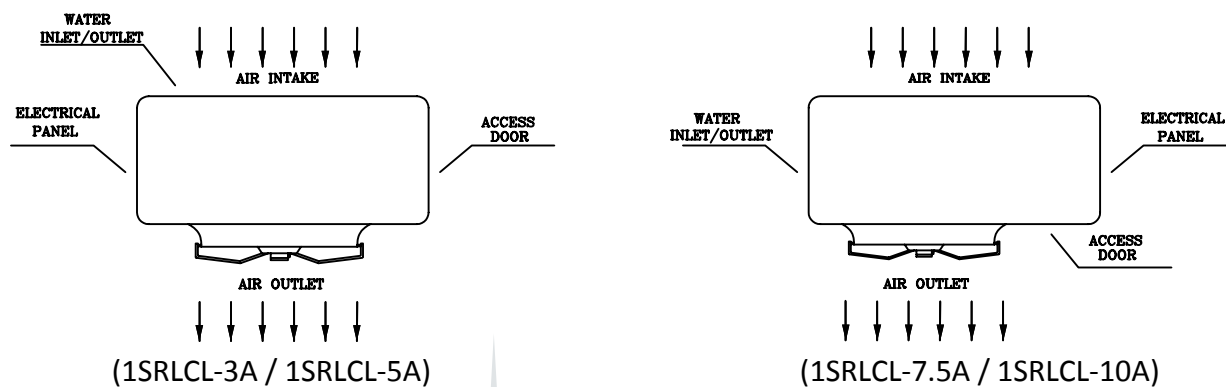



Dimensions

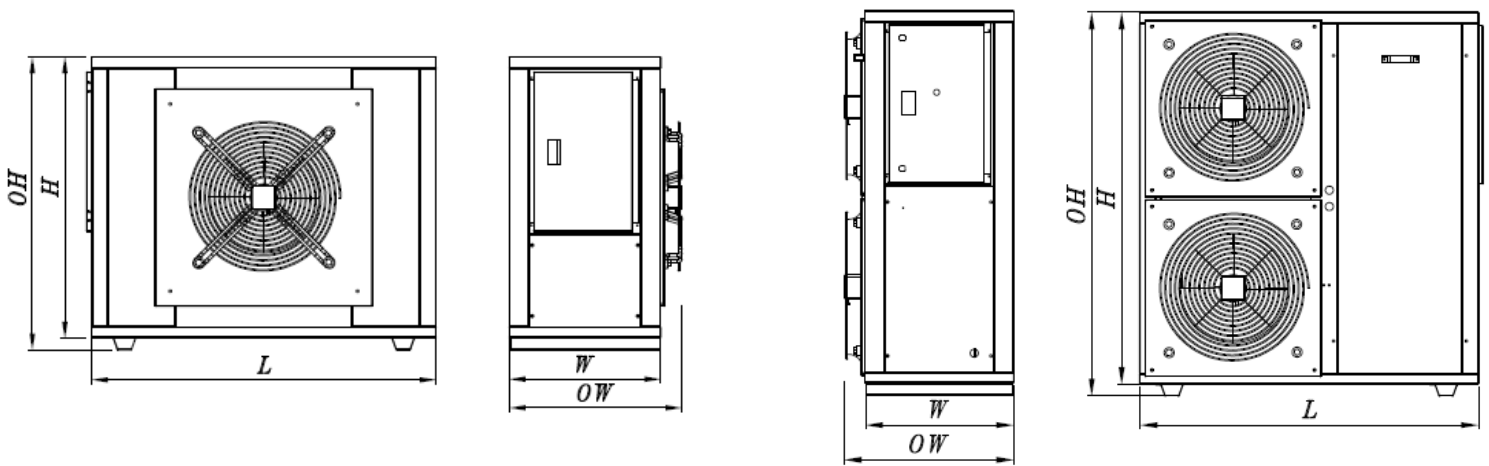

1SRLCL-3A & 1SRLCL-5A

1SRLCL-7.5A & 1SRLCL-10A

Model	L	W	OW	H	OH
1SRLCL-3A	1250	550	780	1020	1060
1SRLCL-5A	1250	550	780	1020	1060
1SRLCL-7.5A	1250	550	740	1365	1410
1SRLCL-10A	1250	550	740	1365	1410

NOTE

- All Dimensions are in millimeter
- The above data is subject to change without notice.